

# OCS<sup>2</sup> FILTER CARTRIDGE

DELIVERS QUALITY WATER FOR COFFEE APPLICATIONS

OCS<sup>2</sup> Replacement Cartridge: EV9618-02



## APPLICATIONS

- ◆ Coffee
  - Low flow, medium volume brewers

## FEATURES • BENEFITS

- ◆ Unique filter blend by Pentair™ Everpure™ uses activated carbon to reduce chlorine taste & odor and other offensive odors
- ◆ Easy, sanitary, quick-change filter replacement
- ◆ Saves energy by reducing scale buildup\*
- ◆ Exclusive precoat filtration provides chlorine taste & odor reduction, and micro-filters dirt and particles as small as 0.2\*-micron in size by mechanical means
- ◆ Proprietary Pentair Everpure Micro-Pure® II filtration media effectively inhibits the growth of bacteria on the filter media that can decrease product life
- ◆ Reduces cysts such as *Cryptosporidium* and *Giardia* by mechanical means

## INSTALLATION TIPS

- ◆ Install vertically so cartridge hangs down.
- ◆ Allow 2½" (6.35 cm) clearance below the cartridge for easy cartridge replacement.
- ◆ Flush filter by running water through filter according to cartridge instructions.

## OPERATION TIPS

- ◆ Replace cartridge when flow rate becomes inconveniently slow or before rated capacity is reached. It is recommended to replace cartridge at least once per year.
- ◆ Change cartridges when capacity is reached or when pressure falls below 10 psi (0.7 bar).
- ◆ Always flush the filter cartridge at time of installation and cartridge change.

## SIZING

- ◆ Service Flow Rate:  
Maximum 0.5 gpm (1.9 Lpm)
- ◆ Rated Capacity:  
1,500 gallons (5,678 L) or 3,000 pots

\* As tested by Pentair

† Validated by ISO 17025 accredited lab for 99.999% reduction of *Pseudomonas diminuta* following the ASTM F838-05 protocol for the validation of 0.2 µm sterilizing grade filters.

EPA Est. No. 002623-IL-002

# OCS<sup>2</sup> REPLACEMENT CARTRIDGE

EV9618-02

OCS<sup>2</sup> Replacement Cartridge: EV9618-02

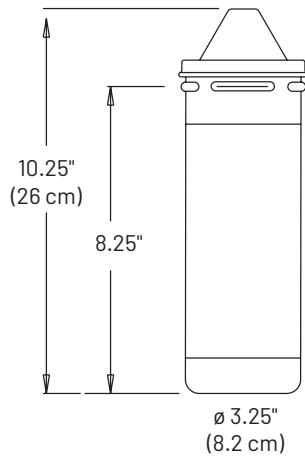

## SPECIFICATIONS

- ◆ **Service Flow Rate**  
Maximum 0.5 gpm (1.9 Lpm)
- ◆ **Rated Capacity**  
1,500 gallons (5,678 L) or 3,000 pots
- ◆ **Pressure Requirements**  
10 - 125 psi (0.7 - 8.6 bar), non-shock
- ◆ **Temperature**  
35 - 100°F (2 - 38°C)
- ◆ **Overall Dimensions**  
10.25" L x 3.25" D (26.0 cm x 8.2 cm)
- ◆ **Electrical Connection**  
None required

The contaminants or other substances removed or reduced by this drinking water system are not necessarily in your water. Do not use with water that is microbiologically unsafe or of unknown quality without adequate disinfection before or after the system.

Since the conditions under which our products may be used are beyond our control, we cannot accept any liability with respect to the improper installation, application and/or use of our products.

For Pentair Everpure Product Warranties visit:  
<http://pentair.com/assets/foodservice-warranty>



System Tested and Certified by NSF International against NSF/ ANSI Standards 42 and 53 for the reduction of:

STANDARD NO. 42 – AESTHETIC EFFECTS Bacteriostatic Effects Chemical Reduction Taste & Odor Chlorine Mechanical Filtration Nominal Particulate Class I	STANDARD NO. 53 – HEALTH EFFECTS Mechanical Filtration Cyst Asbestos
--	--

**United States** | 1040 Muirfield Drive | Hanover Park, IL 60133 | 800.942.1153 (US Only) 630.307.3000 Main | [cseverpure@pentair.com](mailto:cseverpure@pentair.com) | [foodservice.pentair.com](http://foodservice.pentair.com)  
**Australia** | 1-21 Monash Drive | Dandenong South, Vic 3175 | Australia | 011.1300 576 190 Tel | [au.everpure@pentair.com](mailto:au.everpure@pentair.com)  
**China** | 21F Cloud 9 Plaza, N0 1118 | Shanghai, 200052 | China | 86.21.3211.4588 Tel | [china.water@pentair.com](mailto:china.water@pentair.com)  
**India** | Boulevard, B-9/A, 7th Floor - Tower B Sector 62 | Noida - 201301 | 91.120.419.9444 Tel | [indiacustomer@pentair.com](mailto:indiacustomer@pentair.com)  
**Europe** | Pentair Water Belgium BVBA | Industriepark Wolfstee, Toekomstlaan 30, B-2200 Herentals | Belgium | +32.(0).14.283.504 Tel | [sales@everpure-europe.com](mailto:sales@everpure-europe.com)  
**Japan** | Japan Inc. | Hashimoto MN Bldg. 7F, | 3-25-1 Hashimoto, Midori-ku, Sagamihara-shi | Kanagawa 252-0143 | Japan | 81.(0)42.775.3011 Tel | [info@everpure.co.jp](mailto:info@everpure.co.jp)  
**Southeast Asia** | 390 Havelock Road, | #04-01 King's Centre | Singapore 169662 | 65.6768.5800 Tel | [cseverpure@pentair.com](mailto:cseverpure@pentair.com)

All indicated Pentair trademarks and logos are property of Pentair. Third party registered and unregistered trademarks and logos are the property of their respective owners.